



LED BIKE LIGHT SET

GB IE

LED BIKE LIGHT SET
Operation and Safety Notes

DE AT CH

LED-FAHRADLEUCHTEN-SET
Bedienungs- und Sicherheitshinweise

DK

LED-CYKELLYGTESÆT
Brugs- og sikkerhedsanvisninger

IAN 275453

Model-No. 14123

GB IE DK

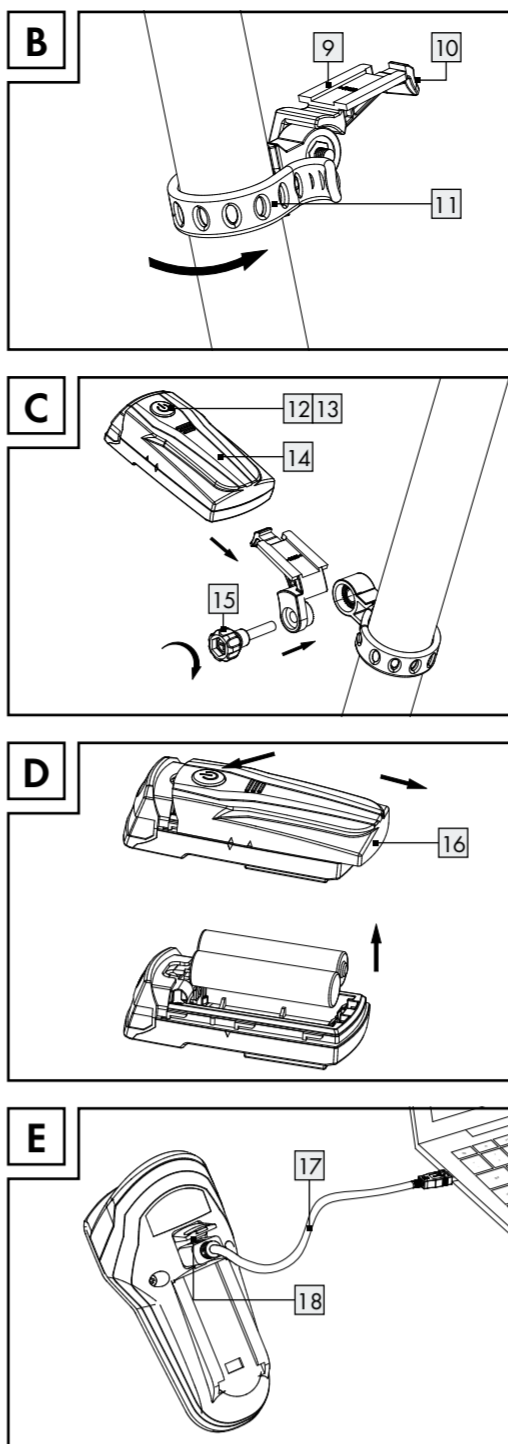
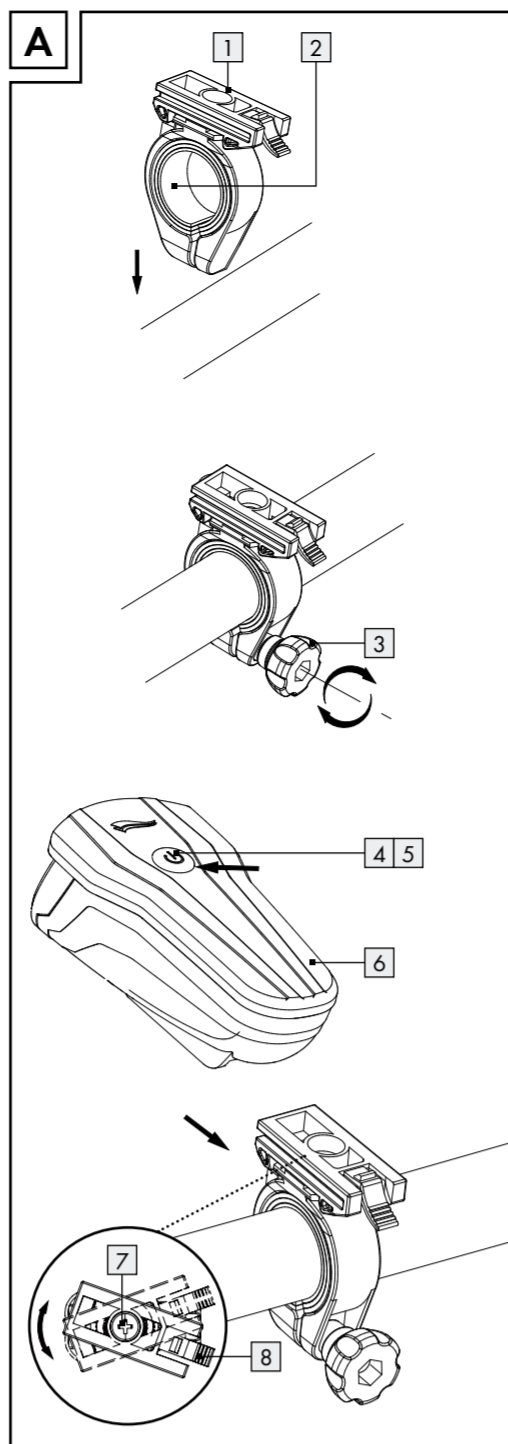

LED Bike Light Set

Introduction

Congratulations on the purchase of your new device. In doing so you have chosen a top-quality product. The instructions for use are to be considered as part of this product. It contains important safety, assembly and disposal information. Before using the product, please familiarise yourself with all the safety information and instructions for use. The product must only be used as described and for the specified fields of application. If you pass the product on to anyone else, please be sure to also include all documentation.

Intended use

This product is suitable for lighting the roadway whilst cycling. The LED Bicycle Light Set is approved as exclusive lighting for all bicycles. Light distribution must not be impaired by other bicycle parts or luggage. The product is intended for outdoor use. Any use other than the aforementioned or any product modification is prohibited and can result in injuries and product damage. The manufacturer is not liable for damages resulting from improper use. This product is not intended for commercial use.

Parts Description

- 1 Headlight bracket
- 2 Reducer rubber
- 3 Headlight bracket retaining screw
- 4 Headlight on/off switch
- 5 Headlight battery/rechargeable battery control light
- 6 Headlight
- 7 Headlight angle adjustment screw
- 8 Headlight lock
- 9 Tail light bracket
- 10 Tail light lock
- 11 Tail light bracket rubber tab
- 12 Tail light on/off switch
- 13 Tail light battery control lamp
- 14 Tail light

- 15 Tail light retaining screw
- 16 Tail light battery cover
- 17 USB cable
- 18 Charging socket

Scope of delivery

- 1 Headlight
- 1 Tail light
- 1 Headlight bracket
- 1 Tail light bracket
- 2 Batteries AAA
- Reducer rubbers
- 1 USB cable
- 1 Instructions for assembly and use

Technical Data

Headlight
Model designation: XC-195A/LI-1
Rated output: 1W
Protection type: IP44 according to DIN EN 60529
Rechargeable Li-ion battery: 1300mAh, 3.7V

Tail light
Model designation: XC-117D/D-LED 3
Rated output: 0.2W
Protection type: IP44 according to DIN EN 60529
Batteries: 2 x 1.5V AAA LR03

Note: Only use rechargeable 1.2V batteries or comparable 1.5V alkaline batteries for the rear light.

Safety instructions

- WARNING! DANGER TO LIFE AND RISK OF ACCIDENT FOR INFANTS AND CHILDREN!** Never leave children unsupervised with the packing material due to the suffocation hazard posed by swallowing parts thereof. Children frequently underestimate the dangers.

- Always keep the product away from children. This product is not a toy!
- This product is not intended to be used by persons (including children) with impaired physical, sensory or mental capacity, or lacking experience or knowledge unless supervised by a person responsible for their safety. Please note, damages caused by incorrect handling, non-compliance with the operating instructions or interference with the device by unauthorised individuals are excluded.
- Never take the product apart. Improper repairs may result in considerable danger to the user. Repairs should only be carried out by specialist personnel. The LED lights are not replaceable.
- WARNING! RISK OF LOSS OF LIFE AND ACCIDENT!** Using the incorrect charger may cause the headlight [6] to be damaged, overheat or even explode. Doing so will void the warranty.

- Failure to observe this notice may result in deep charging the batteries. This poses a risk of leaking. If the batteries have leaked inside the product, please remove them immediately to prevent product damage!
- Avoid contact with the skin, eyes and mucous membranes if fluid has leaked from the batteries/rechargeable battery. In the event of contact with battery acid, thoroughly flush the affected area with clean water and seek immediate medical attention.
- Never recharge single-use batteries! Explosion hazard!
- Note:** If the red rechargeable battery/battery control light [5] [13] on the headlight [6] or the tail light [14] lights up, please replace the batteries or recharge the rechargeable batteries immediately.
- Please note, once the battery indicator lights up, the lights no longer comply with the Road Traffic Act.

- Tighten and hook in the rubber tab [11]
- Loosen the retaining screw [15] on the bracket [9] and adjust to the desired angle.
- Then tighten the screw. Tighten the screw hand tight. To prevent damage, do not use tools for this step.
- Slide the tail light [14] into the bracket [9] until you hear it lock into place.
- To release the tail light [14], pull down on the tail light lock [10] and slide off the tail light [14].

Inserting batteries into the tail light (see Fig. D)

- Slide the battery cover [16] off to the back.
- Insert the batteries into the tail light (2 x AAA 1.5V). Ensure the correct polarity.
- Then reassemble the light.

Operation

Switching on / off

The headlight [6] has three brightnesses.

| On/Off switch | |
|-------------------|--|
| press once | Power mode (40 Lux) for riding in unlit areas |
| press twice | Standard mode (20 Lux) for riding in lit areas |
| press three times | Eco mode (10 Lux) for riding in well lit areas |
| press four times | off |

Charging the headlight (see Fig. E)

- Remove the rubber cover from the battery charging socket [18] and connect the USB cable [17] to the battery charging socket [18].
- Then connect the USB cable [17] to a computer/laptop/standard USB charger with 5V DC and 500-1000mA. Using chargers with different specifications can damage the

LED-cykellygtesæt

Indledning

Hjerteligt tillykke med købet af deres nye apparat. Dermed har De besluttet Dem for et førsteklases produkt. Betjeningsvejledningen er en bestanddel af dette produkt. Den indeholder vigtige henvisninger i forbindelse med sikkerhed, montage og bortskaffelse. Gør Dem fortløftlig med alle betjenings- og sikkerhedshenvisninger inden første brug af produktet. Brug kun produktet som beskrevet og kun til de dertil oplyste formål. Udlever alle dokumenter, når produktet gives videre til tredjemand.

Formålsbestemt anvendelse

Produktet er egnet til kørebanebelysning i forbindelse med cykling. LED-cykellygtesættet er tilladt til alle cykler som eneste belysning. Lysfordelingen må ikke forhindres gennem andre cykel- eller bagagedele. Produktet er beregnet til udendørs brug. En anden anvendelse end før beskrevet eller en ændring af produktet er ikke tilladt og kan føre til skader og beskadigelser af produktet. For skader, som er opstået i forbindelse med u hensigtsmæssig anvendelse overtager producenten ikke nogen hæftelse. Produktet må ikke anvendes til erhvervs mæssige formål.

Beskrivelse af de enkelte dele

- 1 Holder projektor
- 2 Reduktionsgummier
- 3 Holderskrue projektorholder
- 4 Tænd-/slukkontakt projektor
- 5 Akku-/batteri-kontrollampe projektor
- 6 Projektor
- 7 Vinkeljusteringskrue projektor
- 8 Projektørfastlås mekanisme
- 9 Holder baglygte
- 10 Baglygtefastlås mekanisme
- 11 Gummilaske holder baglygte
- 12 Tænd-/slukkontakt baglygte
- 13 Batteri-kontrollampe baglygte
- 14 Baglygte

rechargeable battery, thus the headlight. Doing so will void the warranty.

- The headlight [6] has a battery indicator. If the indicator lights up red, the rechargeable batteries are drained. The indicator will light up green whilst charging. When the rechargeable batteries are ready to be used again, the indicator will extinguish and you can use the headlight [6].
- For the included rechargeable batteries to operate at full power, please do not charge the battery for less than 10 hours the first time. Please do not stop charging sooner, even if the LED is already extinguished. After this, a charging time of approx. 3.5 hours is recommended for rechargeable batteries with 1300mAh.

Cleaning and Care

- Never fully immerse the lights. Do not use corrosive or abrasive cleaning agents. Doing so will damage the lights.
- Clean the LED bicycle light set with a slightly damp, lint-free cloth.

Disposal

The packaging is made of environmentally friendly materials, which may be disposed of through your local recycling facilities.

Contact your local refuse disposal authority for more details on how to dispose of your worn-out product.

To help protect the environment, please dispose of the product properly, not without household waste, when it has reached the end of its useful life. Please contact your local authority for information on collection points and their opening hours.

Defective or used batteries/rechargeable batteries must be recycled according to 2006/66/EC and its amendments. Return batteries/rechargeable batteries and/or the appliance using the recycling facilities provided.

- 15 Holderskrue baglygteholder
- 16 Batteriumslag baglygte
- 17 USB-kabel
- 18 Akku-ladebøsning

Leverede dele

- 1 projektor
- 1 baglygte
- 1 holder projektor
- 1 holder baglygte
- 2 batterier AAA
- reduktionsgummier
- 1 USB-kabel
- 1 montage- og betjeningsvejledning

Tekniske data

Projektor
Type-betegnels: XC-195A/LI-1
Nominel effekt: 1W
Beskyttelsesart: IP44 iht. DIN EN 60529
Li-Ion-akku: 1300mAh, 3,7V

Baglygte
Type-betegnels: XC-117D/D-LED 3
Nominel effekt: 0,2W
Beskyttelsesart: IP44 iht. DIN EN 60529
Batterier: 2 x 1,5V AAA LR03

Henvisning: Anvend ved baglygten venligst udelukkende akkumulatorer med 1,2V eller lignende alkaline batterier med 1,5V.

Sikkerhedshenvisninger

- ADVARSEL! LIVSFARE OG RISIKO FOR TILSKADEKOMST FOR SMÅBØRN OG BØRN!** Lad børn aldrig være uden opsyn med forpackningsmateriale, da der består kvælningsfare i forbindelse med slugning af forpackningsdele. Børn undervurderer hyppigt farene.
- Hold produktet altid udenfor børns rækkevidde. Produktet er ikke legetøj!

Environmental damage due to incorrect battery/rechargeable battery disposal!

Never dispose of batteries/rechargeable batteries in your household waste. They may contain toxic heavy metals and are subject to hazardous waste regulations. The chemical symbols of the heavy metals are: Cd = cadmium, Hg = mercury, Pb = lead. Therefore, dispose of used batteries/rechargeable batteries through your local collection site.

Improper battery disposal destroys valuable resources and the hazardous substances in the batteries may pose a significant danger to the health and environment. Separate collection/disposal of old batteries prevents dangers to the health and environment, and valuable resources regained by recycling.

Warranty

Dear customer, This device is covered by a 3-year warranty from the date of purchase. In the event of product defects, you have legal rights against the retailer of this product. Your statutory rights are not limited in any way by our warranty detailed below.

Warranty terms

The warranty period begins on the date of purchase. Please retain the original receipt safely. This documentation is required as the proof of purchase. Should a defect in material or manufacture occur within three years from the date of purchase of this product, we will repair or replace - at our choice - it free of charge. This warranty is conditional on the defective device and the receipt of purchase being presented within the three year warranty period, and that there is a brief written description of the nature of the defect and of the date it arose. If the defect is covered by our warranty, you will receive the repaired product or a replacement. A repair or exchange of the device does not extend a new warranty period. The warranty period will not be extended by repairs made under warranty. This also applies to replaced and repaired parts. Any damage or defects

present at the time of purchase must be reported immediately after unpacking. Repairs made after the expiration of the warranty period are subject to payment.

Extent of warranty

The device was manufactured to strict quality guidelines and diligently inspected prior to shipment. The warranty applies to defects in material or manufacture. This warranty does not apply to product parts subject to regular wear and therefore considered wear parts or damage to fragile parts, e.g. switches, rechargeable batteries, or made from glass. This warranty becomes void if the device has been damaged or improperly used or maintained. Proper use of the product requires strictly observing all instructions for use. Purposes and practices which the operating instructions warn of or advise against must be avoided without fail. This product is only intended for private, non-commercial use. Any incorrect or improper use of the device, use of force and changes not performed by our authorized service branch will void the warranty. Please follow the instructions below to ensure your claim is processed quickly:

- Please have your receipt and the product number ready as your proof of purchase.
- Please refer to the type plate or the cover sheet of these instructions for the product number.
- In the event of malfunctions or other defects, please first contact the following service department by phone or e-mail.
- A product determined defective may then be returned to the specified service address free of charge, including the proof of purchase (receipt) and information about the defect and when it occurred.
- Please note, the service department must be notified before returning the product!

This and many other manuals, product videos and software are available for download at www.lidl-service.com.

GB
KLB GmbH
Diekbree 8
48157 Münster, Germany
Tel: +49 2 51 132 37 57
E-Mail: gb@klb-service.eu
www.klb-service.eu

IAN 275453

IE
KLB GmbH
Diekbree 8
48157 Münster, Germany
Tel: +49 2 51 132 37 57
E-Mail: ie@klb-service.eu
www.klb-service.eu

IAN 275453

GB/IE

GB/IE

GB/IE

GB/IE

DK

DK

